



Witt

Publication No. WT-WDX-0221A
Supersedes Pub. WT-WDS-0816A

Multicon SMALL AIR COOLED CONDENSER



Efficient and Reliable

Witt's Remote Air Cooled Condensers' innovative design provides a wide array of solutions focusing on performance, energy efficiency, reduced sound output and other requirements to meet the needs of the grocery, supermarket, industrial cooling and commercial warehousing industries.

Standard Features

- Direct drive motor arrangement
- Vertical air flow
- 1075 or 850 RPM motors
- Motors with inherent thermal overload protection
- Copper tube, aluminum fin coils
- Leak tested at 450 PSIG
- Vinyl coated heavy gauge steel fan guards
- Heavy gauge galvanized steel construction for superior corrosion resistance
- Internal divider isolates fan cells (2 fan models)

Options

- Fan cycling head pressure control (2 fan models)
- Variable speed fan control (header end fan only)
- Flooded head pressure control
- Sub-cooling circuit
- Horizontal air flow
- Multi-circuited coils
- Wide selection of fin coatings and materials

MODEL NUMBER NOMENCLATURE

W I	D II	S III	007 IV	D V	A VI	2 VII	B VIII	1 IX	2 X	A XI	1 XII	A XIII
----------------------	-----------------------	------------------------	-------------------------	----------------------	-----------------------	------------------------	-------------------------	-----------------------	----------------------	-----------------------	------------------------	-------------------------

I. Model Series

W – Witt

II. Unit Type

D – Condenser

III. Series

S – Single fan wide

IV. Capacity – Three Number Characters

V. Voltage Code

A – 115V/1/60

G – 460V/3/60

D – 208-230V/1/60

X – Other

E – 208-230V/3/60

Codes D, E, F, and G can be used with 50 or 60 Hz power

F – 460V/1/60

VI. Motor/Fan Type

A – 1075 RPM, 0.33 HP, Metal Blade

C – 850 RPM, 0.25 HP, Metal Blade

H – 1075 RPM, 0.5 HP Totally Enclosed, Metal Blade

X – Other

VII. Length in Fans – 1 or 2

VIII. Coil Density

A – 8 fpi

B – 10 fpi

C – 12 fpi

D – 14 fpi

X – Other

IX. Coil Material and Coating Options*

1 – Aluminum fins

2 – Copper fins

3 – Al + AST coating

6 – Al + Heresite

7 – Al + Polyester coat - Pre Coated Fin Material

X – Other

X. Housing Material and Coatings*

1 – Aluminum

7 – Stainless Steel 316L

2 – Galvanized

X – Other

XI. Unit Design Configuration

A – Vertical Fan Discharge, Standard Legs

E – Vertical Fan Discharge, 30" Legs

N – Horizontal Fan Discharge, Standard Legs

XII. Circuit Splitting Options

1 – Full

2 – 50/50

X – Other

XIII. Revision Code – Single Alphanumeric Character

A – Initial Release

* Contact Application Engineering to obtain price quotes for special fin materials or coatings.

Table of Contents

	Page(s)
Features and Options Chart	3
Condenser Selection Procedure	4-5
Head Pressure Control Option	6
Performance and Specifications	
Physical Dimensions and Drawings	6
1140 RPM Models	7
850 RPM Models	8

Small Air Cooled Condensers

Features and Options

		DESCRIPTION		
GENERAL CONSTRUCTION	Vertical Air Discharge Configuration		STANDARD	
	Horizontal Air Discharge Configuration*		OPTIONAL	
	Galvanized Steel Casing		STANDARD	
	Aluminum Casing		OPTIONAL	
	Protective Coating for External Casing		OPTIONAL	
	Heavy Gauge Galvanized Steel Legs		Vertical Discharge - Leg Length 15" Vertical Discharge - Leg Length 30"	STANDARD OPTIONAL
CONDENSER COIL AND CIRCUITING	Aluminum Tube Sheets		STANDARD	
	Copper Tubes Mechanically Expanded into Aluminum Fins		STANDARD	
	Leak tested at 450 PSIG		STANDARD	
	Coil Circuiting:	Single Circuit		STANDARD
		50/50		OPTIONAL
Multi-Circuiting		OPTIONAL		
Sub-Cooling Circuits		OPTIONAL		
FIN MATERIALS, SPACING AND COATINGS	Fin Spacing:	10 Fins per inch	STANDARD	
		8, 12 or 14 Fins Per Inch	OPTIONAL	
	Fin Materials:	Aluminum Fins	STANDARD	
		Copper Fins or Polyester-Coated Fin Stock	OPTIONAL	
Fin Coatings:	None	STANDARD		
	ElectroFin® or Heresite, or Energy Guard	OPTIONAL		
FAN/ MOTOR	Welded Heavy Gauge Rod Mounting Frame		STANDARD	
	Fully Baffled Fan Modules		STANDARD	
	Motor Type:	Open Type	STANDARD	
Enclosed		OPTIONAL		
ELECTRICAL PANEL	Mounting Location:	Opposite Header End	STANDARD	
		Left hand or Right hand (viewing header) or Header End	OPTIONAL	
	Temp. or Press. Fan Cycling (2 fan models only)		OPTIONAL	
Variable Speed Header End Fan Control - Pressure Controlled		OPTIONAL		
REFRIGERANT SPECIALTIES	Flooded-Condenser Control Valve System (Loose)		OPTIONAL	
SHIPPING	Vertical Air Discharge Models - Legs Disassembled - Unit in Carton or Crate		STANDARD	
	Horizontal Discharge Models* - Legs Disassembled - Unit in Carton or Crate		OPTIONAL	

* Horizontal discharge orientation is available using standard leg arrangement.

Condenser Selection

Air-cooled condenser capacity ratings are based on the total heat rejection of the refrigeration system. Total heat of rejection is the sum of the net refrigeration effect and heat of compression added to the refrigerant in the compressor.

The heat of compression varies with the compressor design, so the compressor manufacturer's information should be used whenever possible. If the compressor manufacturer's heat of compression information is not available, Tables 1 and 2 (page 5) may be used to determine the heat of compression.

The following formulas may be used to calculate the total heat rejection (THR) for systems that fall outside the normal limits of single stage compressor applications, such as compound or cascade systems.

Suction cooled hermetic compressors:

$$\text{THR} = \text{Compressor Capacity (BTUH)} + (3,413 \times \text{KW})$$

Open Compressors

$$\text{THR} = \text{Compressor Capacity (BTUH)} + (2,545 \times \text{BHP})$$

ELEVATION CORRECTION

Elevation above sea level has an effect on the performance of air cooled condensers. Divide the required capacity by the Elevation Correction Factor in the table on page 5 to correct the requirement to Sea Level Conditions. The proper condenser can then be selected from the appropriate table on Pages 7 or 8.

SINGLE CIRCUIT CONDENSERS

All units are available for single circuit applications.

SELECTION EXAMPLE

Given:

- Ambient Air Temperature = 95° F
- Maximum Condensing Temperature = 110° F
- Evaporator Temperature = 20° F
- Refrigerant = R-404A
- Compressor Capacity = 50,000 BTU
- Compressor Type = Suction Cooled Semi-Hermetic

Solution:

Multiply the compressor capacity by the heat of compression factor to calculate the required total heat of rejection (THR). Table 1 shows that for 110°F condensing temperature and 20° F evaporator temperature, the heat of compression factor is 1.33. The required total heat rejection (THR) is:

$$50,000 \times 1.33 = 66,500 \text{ BTUH THR}$$

Divide the THR by the design condensing temperature of 15°F TD. (TD = Condensing Temperature - Ambient Temperature)

$$66,500 \div 15 = 4,433 \text{ BTUH per } 1^\circ\text{F TD}$$

Convert BTUH to MBH.

$$4,433 \text{ BTUH} \div 1,000 = 4.43 \text{ MBH per } 1^\circ\text{F TD}$$

The correct selection of a single fan width unit with 1140 RPM fan motors (page 7) is a model WDS007*A2B12A1A with a capacity of 4.6 MBH @ 14FPI.

Since the unit selection will almost never have the exact required capacity, the actual TD will vary slightly from the design TD. The actual TD can be calculated using the following formula:

$$\text{Actual TD} = \frac{\text{Design THR}}{\text{Actual Condenser THR}} \times \text{Design TD}$$

For this example the actual TD would be:

$$\text{Actual TD} = \frac{4.43}{4.6} \times 15 = 14.4^\circ\text{FTD}$$

Small Air Cooled Condensers

Table 1: Heat of Compression Factors

Suction Cooled Compressors

Evap Temp °F	Condensing Temperature °F								
	90	95	100	105	110	115	120	125	130
-40	1.66	1.70	1.73	1.76	1.80	1.90	2.00	†	†
-35	1.61	1.64	1.68	1.70	1.74	1.82	1.90	†	†
-30	1.57	1.60	1.62	1.65	1.68	1.74	1.80	†	†
-25	1.53	1.56	1.58	1.60	1.63	1.67	1.72	†	†
-20	1.49	1.51	1.53	1.55	1.58	1.61	1.65	†	†
-15	1.46	1.48	1.50	1.51	1.54	1.57	1.61	†	†
-10	1.42	1.44	1.46	1.48	1.50	1.53	1.57	1.60	1.64
-5	1.39	1.41	1.43	1.45	1.47	1.50	1.53	1.56	1.60
0	1.36	1.38	1.40	1.42	1.44	1.47	1.50	1.53	1.56
+5	1.33	1.35	1.37	1.39	1.41	1.43	1.46	1.49	1.52
+10	1.31	1.32	1.34	1.36	1.38	1.40	1.43	1.46	1.49
+15	1.28	1.30	1.32	1.33	1.35	1.37	1.40	1.43	1.46
+20	1.26	1.27	1.29	1.31	1.33	1.35	1.37	1.40	1.43
+25	1.24	1.25	1.27	1.29	1.31	1.33	1.35	1.37	1.40
+30	1.22	1.23	1.25	1.26	1.28	1.30	1.32	1.34	1.37
+35	1.20	1.21	1.23	1.25	1.26	1.27	1.29	1.31	1.34
+40	1.18	1.19	1.21	1.23	1.24	1.25	1.27	1.29	1.31
+45	1.16	1.17	1.19	1.21	1.22	1.23	1.25	1.26	1.28
+50	1.14	1.15	1.17	1.19	1.20	1.22	1.23	1.24	1.26

A. † Beyond the normal limits for single stage compressor application.

Table 2: Heat of Compression Factors

Open Compressors

Evap Temp °F	Condensing Temperature °F								
	90	95	100	105	110	115	120	125	130
-30	1.37	1.39	1.42	1.44	1.47	†	†	†	†
-20	1.33	1.35	1.37	1.39	1.42	1.44	1.47	†	†
-10	1.28	1.30	1.32	1.34	1.37	1.39	1.42	1.44	1.47
0	1.24	1.26	1.28	1.30	1.32	1.34	1.37	1.39	1.41
+10	1.21	1.23	1.24	1.26	1.28	1.30	1.32	1.34	1.36
+20	1.17	1.18	1.20	1.22	1.24	1.26	1.28	1.30	1.32
+30	1.14	1.15	1.17	1.18	1.20	1.22	1.24	1.25	1.27
+40	1.12	1.14	1.15	1.16	1.17	1.18	1.20	1.21	1.23
+50	1.09	1.11	1.12	1.13	1.14	1.16	1.17	1.19	1.20

A. † Beyond the normal limits for single stage compressor application.

Table 3: Elevation Correction Factors

Elevation (ft)	1,000	2,000	3,000	4,000	5,000	6,000	8,000	10,000	12,000	14,000	16,000
Correction Factor	0.94	0.93	0.90	0.88	0.86	0.83	0.79	0.75	0.71	0.66	0.62

Head Pressure Control Options

FLOODED CONDENSER

The Flooded Condenser Head Pressure Control Option maintains adequate condensing pressure while operating in low ambient temperatures. By flooding the condenser with liquid refrigerant, the amount of coil surface available for condensing is reduced. The resulting reduction in capacity ensures proper operation of the thermal expansion valve.

This option requires a modulating three-way valve, dependent on refrigerant discharge pressure, be placed at the condenser outlet. A fall in ambient temperature causes a corresponding fall in discharge pressure. The valve modulates allowing discharge gas to flow to the receiver, creating a higher pressure at the condenser outlet. This higher pressure reduces the flow out of the condenser, causing liquid refrigerant to back up in the coil. Flooding the condenser reduces the available condensing surface and raises the condensing pressure so that adequate high-side pressure is maintained.

A larger receiver and additional refrigerant are required for systems with flooded condenser control. The receiver can be conveniently installed directly under the condenser in most applications. However, if the system will be operational in ambient temperatures below 55° F, the receiver should be located in a warm environment or heated. In this situation, a check valve must be installed in the line between the receiver and condenser valve. This prevents refrigerant migration from the receiver to the condenser.

The amount of additional refrigerant charge is based on the lowest expected winter operating temperature and the design TD. In addition to the condenser charge, the operating charges of the evaporator, receiver and refrigerant lines must be added to determine the total system refrigerant charge. The pump-down capacity (80% of full capacity) of the receiver must be at least equal to the total system charge.

Physical Data

Model Number	Drawing	A	B	C	D	E	F
WDS001*A1	WDS001*C1	1	12-1/2	28	25-9/16	13-3/4	26-5/8
WDS002*A1	WDS002*C1	1	12-1/2	28	25-9/16	13-3/4	26-5/8
WDS003*A1	WDS003*C1	1	14-3/8	33	30-9/16	15-5/8	31-5/8
WDS005*A1	WDS004*C1	1	14-3/8	33	30-9/16	15-5/8	31-5/8
WDS007*A2	WDS006*C2	2	14-3/8	66	30-9/16	15-5/8	64-5/8
WDS009*A2	WDS008*C2	2	14-3/8	66	30-9/16	15-5/8	64-5/8
WDS011*A2	WDS009*C2	2	14-3/8	66	30-9/16	15-5/8	64-5/8

DRAWING - 1 FAN

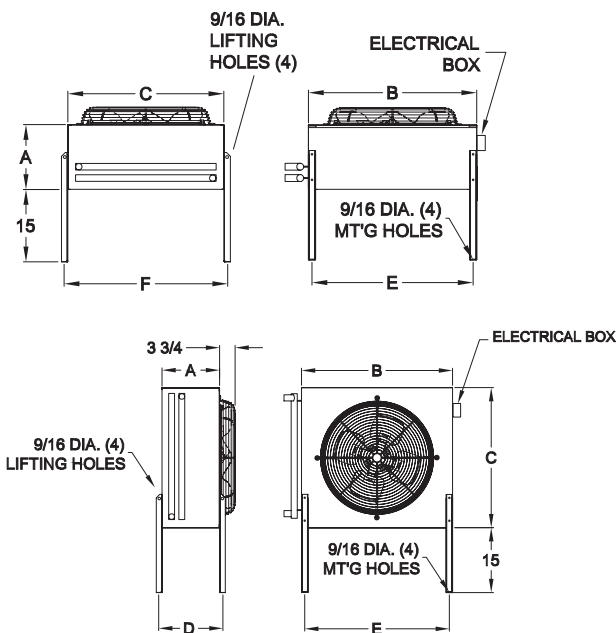

DRAWING - 2 FAN

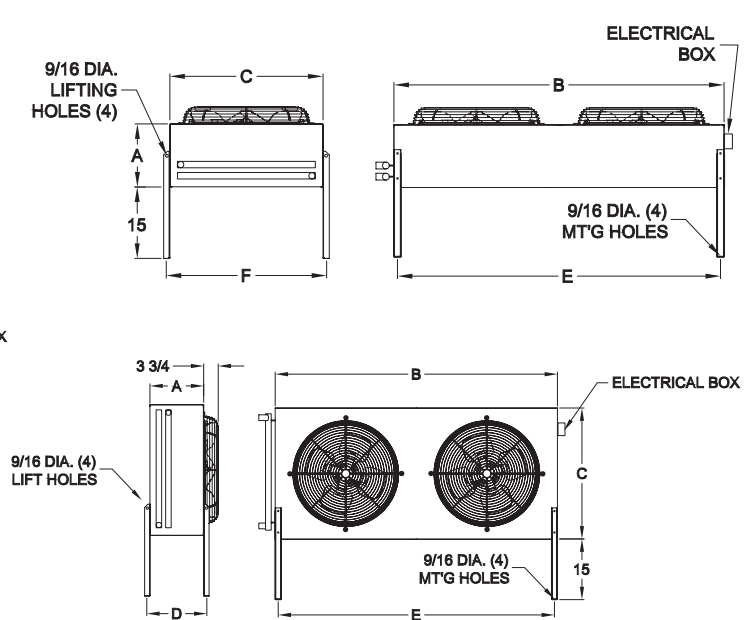

Note: All dimensions are in inches.

Small Air Cooled Condensers

Performance Data - 1075 RPM Fan Motors

THR MBH 1°F TD - R407A

Model Number	Fins Per Inch			
	8	10	12	14
WDS001*A1B12A1A	0.67	0.77	0.82	0.95
WDS002*A1B12A1A	1.16	1.26	1.38	1.48
WDS003*A1B12A1A	1.52	1.72	1.89	2.04
WDS005*A1B12A1A	2.18	2.43	2.61	2.75
WDS007*A2B12A1A	3.25	3.69	4.05	4.37
WDS009*A2B12A1A	4.47	4.98	5.34	5.64
WDS011*A2B12A1A	5.37	5.85	6.16	6.52

THR MBH 1°F TD - R404A & R507

Fins Per Inch			
8	10	12	14
0.73	0.84	0.90	1.04
1.17	1.33	1.45	1.57
1.60	1.81	1.99	2.15
2.23	2.48	2.68	2.81
3.42	3.89	4.27	4.60
5.46	5.06	5.45	5.76
5.31	5.79	6.10	6.45

* Each asterisk represents a variable character based upon voltage and vintage ordered. See page 2 for complete nomenclature.

For R-22 capacity, multiply R404A unit capacity by 1.02

For R-407C capacity, multiply R407A capacity by .98

For R-134a capacity multiply R-404A unit capacity by .97

For R-410A capacity, multiply R404A capacity by 1.08

Notes:

- R-407A ratings are based on Mean Condensing Temperature which is the average of the Dew Point and Bubble Point temperatures corresponding to the refrigerant temperature at the condenser inlet.

Specifications - 1075 RPM Fan Motors

Model Number	Fans				Maximum Circuit Quantity	Connection (Inches) [^]	Connection Quantity	Net Weight (Lbs.)	Unit kW
	Quantity	Diameter	CFM	dBA [†]					
WDS001*A1B12A1A	1	18	3,020	47.0	5	7/8	2	80	0.28
WDS002*A1B12A1A	1	18	2,840	47.0	10	7/8	2	86	0.28
WDS003*A1B12A1A	1	22	4,450	57.0	12	7/8	2	107	0.47
WDS005*A1B12A1A	1	22	3,900	57.0	18	7/8	2	116	0.47
WDS007*A2B12A1A	2	22	8,640	60.0	18	1-1/8	2	164	0.94
WDS009*A2B12A1A	2	22	7,780	60.0	27	1-1/8	2	179	0.94
WDS011*A2B12A1A	2	22	7,080	60.0	36	1-1/8	2	195	0.94

Model Number	208-230/1/60			208-230/3/60			460/1/60			460/3/60		
	FLA	MCA	MOPD	FLA	MCA	MOPD	FLA	MCA	MOPD	FLA	MCA	MOPD
WDS001*A1B12A1A	3.2	15.0	15	1.8	15.0	15	1.3	15.0	15	0.9	15.0	15
WDS002*A1B12A1A	3.2	15.0	15	1.8	15.0	15	1.3	15.0	15	0.9	15.0	15
WDS003*A1B12A1A	3.2	15.0	15	1.8	15.0	15	1.3	15.0	15	0.9	15.0	15
WDS005*A1B12A1A	3.2	15.0	15	1.8	15.0	15	1.3	15.0	15	0.9	15.0	15
WDS007*A2B12A1A	6.4	15.0	15	3.6	15.0	15	2.6	15.0	15	1.8	15.0	15
WDS009*A2B12A1A	6.4	15.0	15	3.6	15.0	15	2.6	15.0	15	1.8	15.0	15
WDS011*A2B12A1A	6.4	15.0	15	3.6	15.0	15	2.6	15.0	15	1.8	15.0	15

* Each asterisk represents a variable character based upon voltage and vintage ordered. See page 2 for complete nomenclature.

† Sound pressure dBA @ 10 feet.

[^] Standard connection sizes are for no circuit split. Header diameters are one size larger than connection sizes.

Variance from standard operating conditions may result in connection sizes which are different from those listed above.

Performance Data - 850 RPM Fan Motors

THR MBH 1°F TD - R407A

Model Number	Fins Per Inch			
	8	10	12	14
WDS001*C1B12A1A	0.63	0.73	0.81	0.90
WDS002*C1B12A1A	1.05	1.19	1.31	1.41
WDS003*C1B12A1A	1.38	1.57	1.72	1.86
WDS004*C1B12A1A	1.97	2.19	2.35	2.49
WDS006*C2B12A1A	2.97	3.37	3.71	4.00
WDS008*C2B12A1A	4.04	4.50	4.82	5.10
WDS009*C2B12A1A	4.69	5.12	5.39	5.70

THR MBH 1°F TD - R404A & R507

Fins Per Inch			
8	10	12	14
0.68	0.79	0.88	0.97
1.09	1.24	1.36	1.47
1.44	1.63	1.79	1.93
1.97	2.19	2.35	2.49
3.09	3.51	3.86	4.16
4.05	4.51	4.83	5.11
4.53	4.94	5.21	5.50

* Each asterisk represents a variable character based upon voltage and vintage ordered. See page 2 for complete nomenclature.
 For R-22 capacity, multiply R404A unit capacity by 1.02
 For R-407C capacity, multiply R407A capacity by .98
 For R-134a capacity multiply R-404A unit capacity by .97
 For R-410A capacity, multiply R404A capacity by 1.08

Notes:

- R-407A ratings are based on Mean Condensing Temperature which is the average of the Dew Point and Bubble Point temperatures corresponding to the refrigerant temperature at the condenser inlet.

Specifications - 850 RPM Fan Motors

Model Number	Fans				Maximum Circuit Quantity	Connection (Inches)^	Connection Quantity	Net Weight (Lbs.)	Unit kW
	Quantity	Diameter	CFM	dBA†					
WDS001*C1B12A1A	1	18	2,470	47.0	5	7/8	2	80	0.11
WDS002*C1B12A1A	1	18	2,110	47.0	10	7/8	2	86	0.11
WDS003*C1B12A1A	1	22	3,290	52.0	12	7/8	2	107	0.20
WDS004*C1B12A1A	1	22	2,880	52.0	18	7/8	2	116	0.20
WDS006*C2B12A1A	2	22	6,390	55.0	18	1-1/8	2	164	0.40
WDS008*C2B12A1A	2	22	5,760	55.0	27	1-1/8	2	179	0.40
WDS009*C2B12A1A	2	22	5,170	55.0	36	1-1/8	2	195	0.40

Model Number	208-230/1/60			208-230/3/60			460/1/60			460/3/60		
	FLA	MCA	MOPD	FLA	MCA	MOPD	FLA	MCA	MOPD	FLA	MCA	MOPD
WDS001*C1B12A1A	1.4	15.0	15	1.1	15.0	15	0.7	15.0	15	0.6	15.0	15
WDS002*C1B12A1A	1.4	15.0	15	1.1	15.0	15	0.7	15.0	15	0.6	15.0	15
WDS003*C1B12A1A	1.4	15.0	15	1.1	15.0	15	0.7	15.0	15	0.6	15.0	15
WDS004*C1B12A1A	1.4	15.0	15	1.1	15.0	15	0.7	15.0	15	0.6	15.0	15
WDS006*C2B12A1A	2.8	15.0	15	2.2	15.0	15	1.4	15.0	15	1.2	15.0	15
WDS008*C2B12A1A	2.8	15.0	15	2.2	15.0	15	1.4	15.0	15	1.2	15.0	15
WDS009*C2B12A1A	2.8	15.0	15	2.2	15.0	15	1.4	15.0	15	1.2	15.0	15

* Each asterisk represents a variable character based upon voltage and vintage ordered. See page 2 for complete nomenclature.

† Sound pressure dBA @ 10 feet.

^ Standard connection sizes are for no circuit split. Header diameters are one size larger than connection sizes.

Variance from standard operating conditions may result in connection sizes which are different from those listed above.

Due to continuing product development, specifications are subject to change without notice.